

Figure 12 – Exhaust Manifold Assemblies

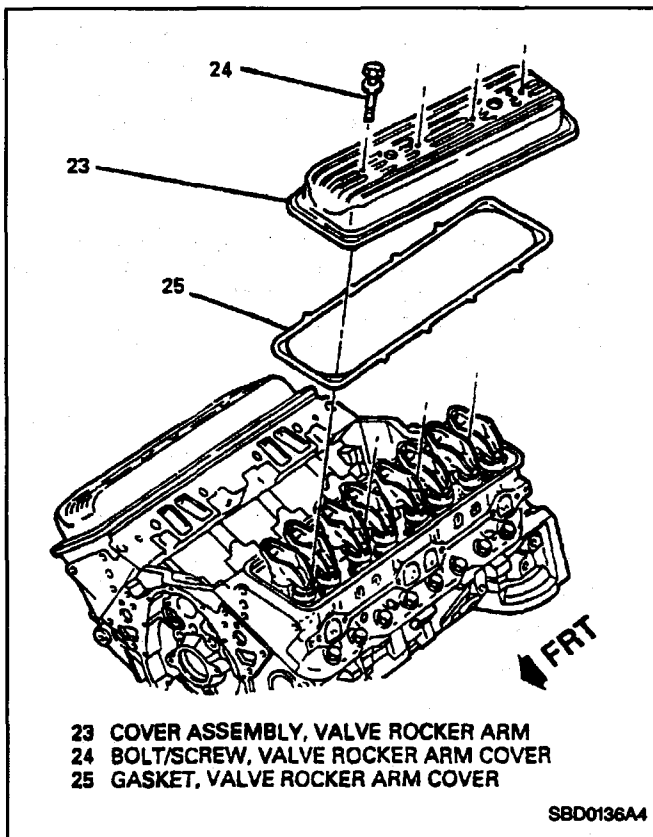

Figure 13 – Valve Rocker Arm Cover Assemblies

- B. Install bearing tool with shoulder toward bearing. Make sure that enough threads are engaged.
 - C. Using two wrenches, hold puller screw while turning nut to draw bearing out of bore.
 - When bearing has been pulled from bore, remove bearing tool and bearing from puller screw.
 - D. Repeat above steps for remaining inner camshaft bearings.
 - Index pilot in rear camshaft bearing to remove rear inner bearing.
3. Front and rear camshaft bearings using J 6098-01.
- A. Assemble bearing tool to driver handle.
 - B. Drive front and rear bearings out, toward center of engine block (67).

CLEANING, INSPECTION AND REPAIR

ENGINE BLOCK

Figure 31

↔ Remove or Disconnect

1. Engine oil cooler assembly (141).
2. Oil filter adapter bolts/screws (143).
3. Oil filter assembly (142).
4. Front and rear oil gallery plugs.