

SECTION 8D

BODY CONTROL MODULE

CAUTION: This vehicle is equipped with Supplemental Inflatable Restraint (SIR). Refer to CAUTIONS in Section 9J under "ON VEHICLE SERVICE" and the SIR Component and Wiring Location view in Section 9J before performing service on or around SIR components or wiring. Failure to follow CAUTIONS could result in possible air bag deployment, personal injury, or otherwise unneeded SIR system repairs.

CONTENTS

General Description.....	8D-1	DTC 22/32-Courtesy Lamps Return (Circuit Shorted to B+).....	8D-14
System Functions	8D-1	DTC 23/33-Retained Accessory Power (RAP) (Circuit Shorted to Ground or B+)	8D-16
Wake-Up/Asleep States	8D-1	DTC 24/34-"Fasten Seatbelt" Indicator Lamp (Circuit Shorted to Ground or B+)	8D-18
Power Requirements.....	8D-2	DTC 25/35-Security L.E.D. Present (With UA6 only).....	8D-20
Abbreviations/Definitions	8D-2	"REMOTE CONTROL DOOR LOCK TRANSMITTER DTCs".....	8D-21
On-Vehicle Service.....	8D-2	DTC 41- Last Transmitter Message Received Valid (With AU0 only)	8D-21
BCM Replacement	8D-2	DTC 42- Last Transmitter Message Received had Invalid ID (With AU0 only).....	8D-21
Component Locations/Removal Procedures	8D-2	DTC 43- Last Transmitter Message Received had Sumcheck Error (With AU0 only)	8D-22
Diagnostics.....	8D-2	DTC 44- Last Transmitter Message Received had Encryption Error (With AU0 only)	8D-22
Entry Into Diagnostics	8D-2	DTC 45- Receiver Processing Currently in 20 Second Lockout (With AU0 only).....	8D-23
Intermittent/History DTCs.....	8D-3	DTC 55-Begin Configuration Display	8D-23
Body Control Module (BCM)			
Replacement/Removal Procedures.....	8D-3		
Clearing BCM DTCs	8D-3		
BCM Wiring Diagrams.....	8D-4		
DTC Display Order.....	8D-6		
BCM DTCs	8D-6		
DTC 12-Begin Diagnostic Display	8D-6		
DTC 21/31-Courtesy Lamps Feed (Circuit Shorted to Ground).....	8D-10		

GENERAL DESCRIPTION

SYSTEM FUNCTIONS

The Body Control Module (BCM) performs the following functions:

- Remote keyless entry.
- Universal theft deterrent system.
- PASS-Key II®.
- Chime.
- "Fasten Seatbelt" Indicator.
- "Low Coolant" Indicator latching.
- Retained Accessory Power (RAP).
- Power Door Locks.
- Hatch Release.
- Courtesy lamp control.
- Illuminated entry.
- Delayed interior lamps.

WAKE-UP/ASLEEP STATES

"Wake-ups" are signals that will turn the BCM "ON" and cause it to begin active control and/or monitoring. The BCM is "asleep" when it has stopped

control or monitoring and has become idle again. The signals that will cause the BCM to wake-up are as follows:

- Courtesy lamp system.
- Remote keyless entry system.
- Ignition "ON" (IGN 1).
- Park Lamps.
- Headlamps.
- Door Jamb Switches.
- Hatch Switch.
- Key in Ignition Switch.
- Shock Sensor Inputs.

After the BCM is awake and the wake-up input is removed (i.e., a door is opened, then closed) the BCM will "go to sleep" again in 10 minutes.

If the BCM sees a door ajar wake-up, and that wake-up remains active (i.e., the door remains open with ignition "OFF") for 10 minutes, the BCM will turn courtesy lamps "OFF," if they were "ON." This is done to prevent battery drain if a door is inadvertently left open for an extended period of time.

POWER REQUIREMENTS

Operating current at the BCMs battery terminals should not exceed 75 milliamps while the BCM is awake with ignition "OFF"; 250 milliamps is an approximate "normal" value with ignition in "RUN". The RAP system allows operation of the Power Door Locks, convertible top and radio until a door is opened or 10 minutes has elapsed. When the BCM is asleep, the current should not exceed 3 milliamps (w/UA6), or 2 milliamps (without UA6). The BCM goes asleep after the ignition is shut "OFF" and 10 minutes has elapsed. Operating current drawn by the IGN 1 and IGN 3 terminals of the BCM should not exceed 15 milliamps. Refer to SECTION 6D1 for more details on BCM current drain in various awake and asleep conditions. For most BCM functions, the BCM will operate properly with a system voltage of 9-16 volts.

ABBREVIATIONS/DEFINITIONS

Several abbreviations are commonly used throughout this section. They are presented here for easy reference.

- BCM..... Body Control Module
- CKT..... Circuit
- DLC.....Data Link Connector
- DTC..... Diagnostic Trouble Code
- DVM..... Digital Voltmeter
- PCM.....Powertrain Control Module
- PASS-Key II® Personal Automotive Security System
- RAP.....Retained Accessory Power
- UTD..... Universal Theft Deterrent

ON-VEHICLE SERVICE

CAUTION: This vehicle is equipped with Supplemental Inflatable Restraint (SIR). Refer to CAUTIONS in Section 9J under "ON-VEHICLE SERVICE" and the SIR Component and Wiring Location view in Section 9J before performing service on or around SIR components or wiring. Failure to follow CAUTIONS could result in possible air bag deployment, personal injury, or otherwise unneeded SIR system repairs.

BCM REPLACEMENT

The BCM should only be replaced if diagnostics in this section, or 8A direct you specifically to do so. Most system concerns are traceable to faulty wiring, connectors, or components; the BCM itself is very reliable, and is not likely the cause of a fault. BCM replacement before complete diagnosis is performed will likely lead to a recurrence of the fault.

The BCM electrical connectors are designed with indexing tabs and slots such that they only fit one way. They do not require excessive force if they are being installed correctly. Installing the connectors in the wrong mating half or upside down can cause damage to the connector, the BCM, or other vehicle components or systems. BCM replacement procedures can be found on Page 8D-3.

COMPONENT LOCATIONS/REMOVAL PROCEDURES

Below is a list of each component that a BCM diagnostic chart may direct you to replace. Use the list to determine which section in the manual contains the removal and replacement procedures for the component in question. Refer to Page 8D-3 for actual BCM replacement/removal procedures.

- BCM.....8D
- PCM..... 6E3
- Instrument Cluster8C
- PASS-Key II® Ignition Key.....9D
- Theft Deterrent Shock Sensor.....9D
- Theft Deterrent L.E.D.9D

DIAGNOSTICS

ENTRY INTO DIAGNOSTICS

The BCM can display a series of DTCs, when it is placed in the diagnostic mode. These DTCs are displayed as flash codes through the "Security" indicator lamp on the Instrument Cluster. During normal operation, if the BCM detects a fault on a monitored circuit, there will be no flashing or any indication to the customer that a fault has occurred, though he/she might detect a system malfunction. The system faults will be recorded as "Current," or "History". A "Current" DTC means that the condition was present when the Diagnostic mode was entered. A "History" DTC means the condition has occurred sometime since the BCM was installed in the vehicle, but may not be present currently. If a "Current" DTC is present, the associated "History" DTC will always be present. When working on systems controlled by the BCM, the technician should always refer to this section and check for DTCs.

Diagnostics is entered by performing the following steps:

- Put the key into the Ignition Switch and turn it to the "RUN" position (to disarm the theft deterrent system, if equipped).
- Turn the Ignition Switch to the "OFF" position.
- Remove the RADIO fuse 17 from the I/P fuse block.
- Turn the Ignition Switch to the "ACC" position (enters "Program" mode for feature customization, 1 or 2 "Chimes" for mode verification).
- Within 5 seconds, turn the Ignition Switch to "OFF" then back to "ACC" position (enters diagnostic mode, 3 "Chimes" for mode verification).

The BCM will begin to flash DTCs 4 seconds after entering the diagnostic mode, from the programming mode. Each flash of the "Security" indicator lamp on the I/P represents a number. For example, one flash followed by two quick flashes represents a code 12. Each code is displayed 3 times before the next code is displayed. Any DTCs present are displayed in numerical order. Once the last code is

displayed, the list begins over again with the first code. The display continues until the Diagnostic Mode is exited.

INTERMITTENT/HISTORY DTCs

History DTCs are those indicating that the BCM previously detected a fault which later disappeared. Any DTC that has a 3 as its first digit is a "History" DTC. Examples are: 31, 32, 33 etc. The reason could be either that the fault is a true intermittent only happening occasionally, or that the system which the DTC monitors is not currently being operated.

If a visual (physical) check does not find the cause of the concern, the vehicle can be driven with a DVM connected to the suspected circuit. An abnormal voltage or resistance reading when the concern occurs indicates the concern may be in that circuit.

**BODY CONTROL MODULE (BCM)
REPLACEMENT/REMOVAL PROCEDURES**

NOTICE:

- If BCM C2 connector is removed first and reinstalled last, no BCM DTCs will set.
- If BCM is being replaced (as opposed to being removed for access to other components), refer to "BCM Replacement" in SECTION 9D after new BCM is installed in vehicle. This will enable the PASS-Key II® system portion of the BCM, to properly code the new BCM to the present ignition key being used.
- The electrical connectors are designed to fit in only one way; there are indexing tabs and slots on both halves of the connector. Forcing the connector into place is not necessary if it being installed with the proper orientation.

Failure to take care to match the indexing tabs and slots to ensure the connector is being installed correctly can cause damage to the connector, the module or other vehicle components or systems.

↔ Remove or Disconnect

1. Lower instrument panel insulator.
2. Unsnap BCM from HVAC duct bracket.
 - Lower BCM.
3. Electrical connectors and remove BCM from vehicle.

⇐ Install or Connect

1. Electrical connectors to BCM.
2. Snap BCM to HVAC duct bracket.
3. Lower instrument panel insulator.

! Important

- G200 ground is the primary ground for the BCM and other electrical components. This ground must be tight at all times, or failure of the BCM could occur.

CLEARING BCM DTCs

"Current" DTCs (21-25) will remain stored and display as long as the BCM detects the fault criteria. "History" DTC (31-35) can be cleared by depressing the door unlock switch for a period of 4 seconds while the BCM is in the Diagnostic Mode. The Chime will sound 3 times at the end of the 4 second period as a confirmation that the DTC(s) have cleared.

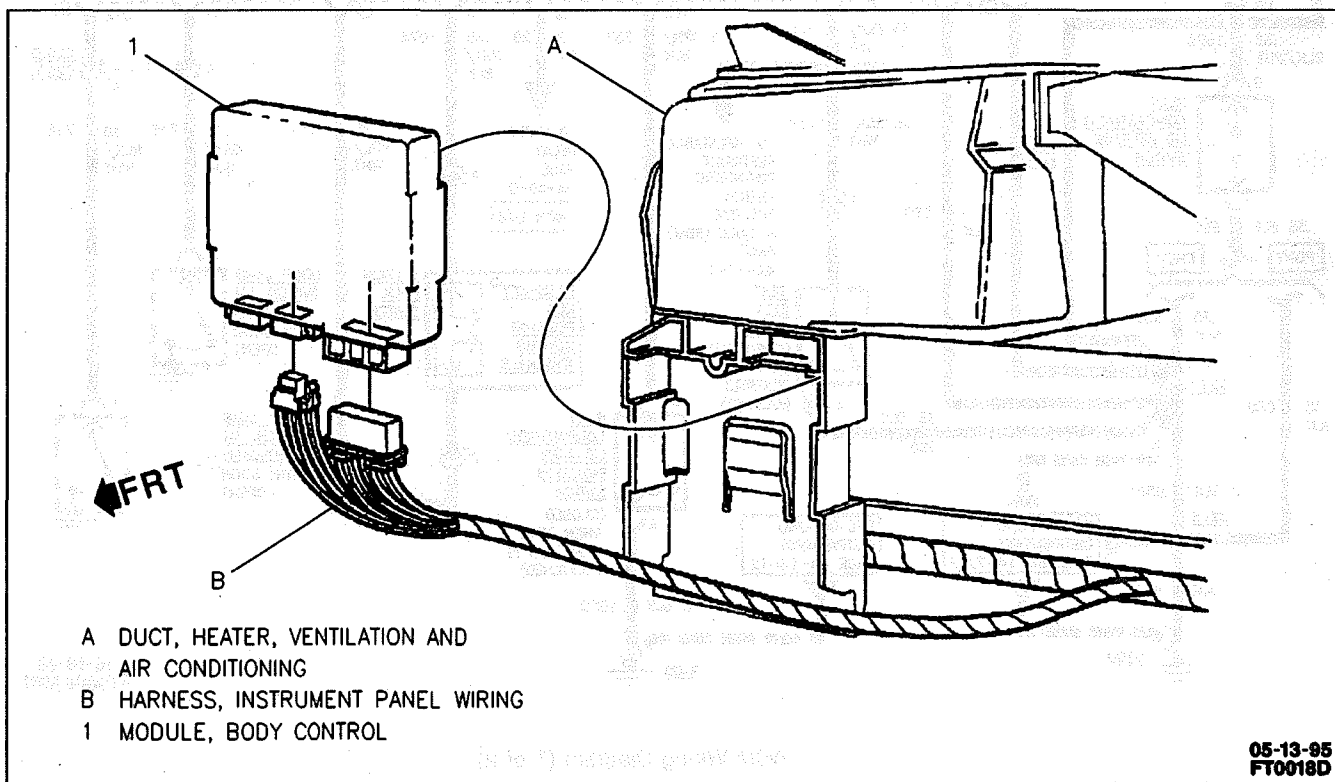
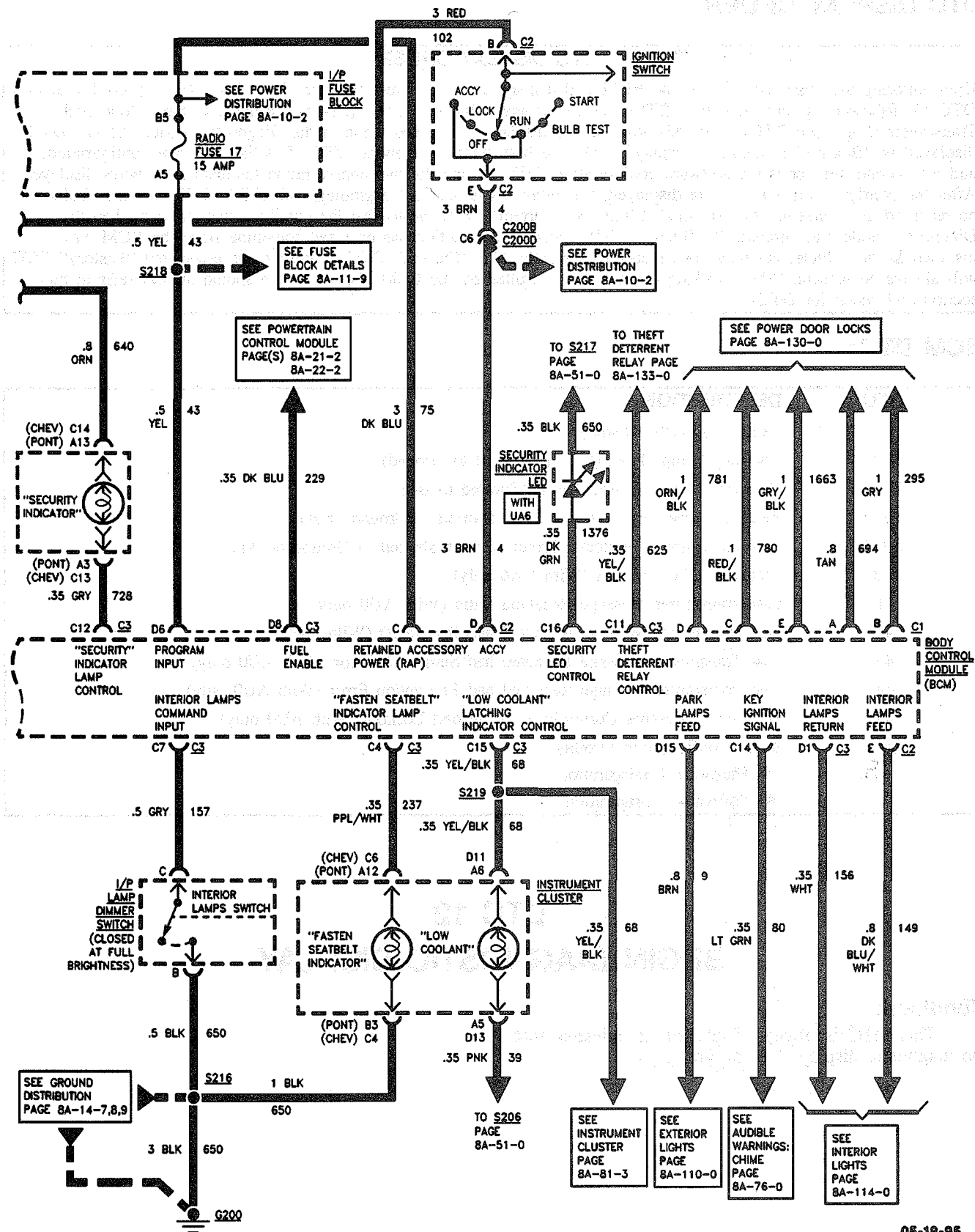

Figure 1 - Body Control Module



05-18-95
FT0018A051

BCM Wiring Diagram (2 of 2)

DTC DISPLAY ORDER**DTC DISPLAY ORDER**

Upon entering the Diagnostic Mode, the BCM will display DTCs in numerical order. The first DTC displayed is always DTC 12, followed by any "Current" DTCs (21-25) or any "History" DTCs (31-35). "Remote Control Door Lock Transmitter Diagnostic DTCs" (41-45) will then be displayed if evoked while in the Diagnostic Mode. The last DTC displayed is "Begin Configuration Display" (55). The first number following DTC 55 is the hardware configuration, and the second number is the software configuration. DTC 55 and the two configuration numbers are always displayed. After the configuration numbers are displayed, the entire list is repeated beginning with DTC 12. The system faults will be recorded as "Current," or "History" DTCs. A "Current" DTC means that the condition was present when the Diagnostic mode was entered. A "History" DTC means the condition has occurred sometime since the BCM was installed in the vehicle, but may not be present currently. If a "Current" DTC is present, the associated "History" DTC will always be present. When working on systems controlled by the BCM, the technician should always refer to this section and check for DTCs.

BCM DTCs

DTC	DESCRIPTION
12	Begin Diagnostic Display
21/31	Courtesy Lamps Feed (Circuit Shorted to Ground)
22/32	Courtesy Lamps Return (Circuit Shorted to B+)
23/33	Retained Accessory Power (Circuit Shorted to Ground or B+)
24/34	"Fasten Seatbelt" Indicator Lamp (Circuit Shorted to Ground or B+)
25/35	Security L.E.D. Present (With UA6 only)
41	Last Transmitter Message Received Valid (With AU0 only)
42	Last Transmitter Message Received had Invalid ID (With AU0 only)
43	Last Transmitter Message Received had Sumcheck Error (With AU0 only)
44	Last Transmitter Message Received had Encryption Error (With AU0 only)
45	Receiver Processing Currently in 20 Second Lockout (With AU0 only)
55	Begin Configuration Display
	-## Hardware Configuration
	-## Software Configuration

DTC 12**BEGIN DIAGNOSTIC DISPLAY****Condition:**

This DTC is always displayed. It indicates that the diagnostic display is in progress.

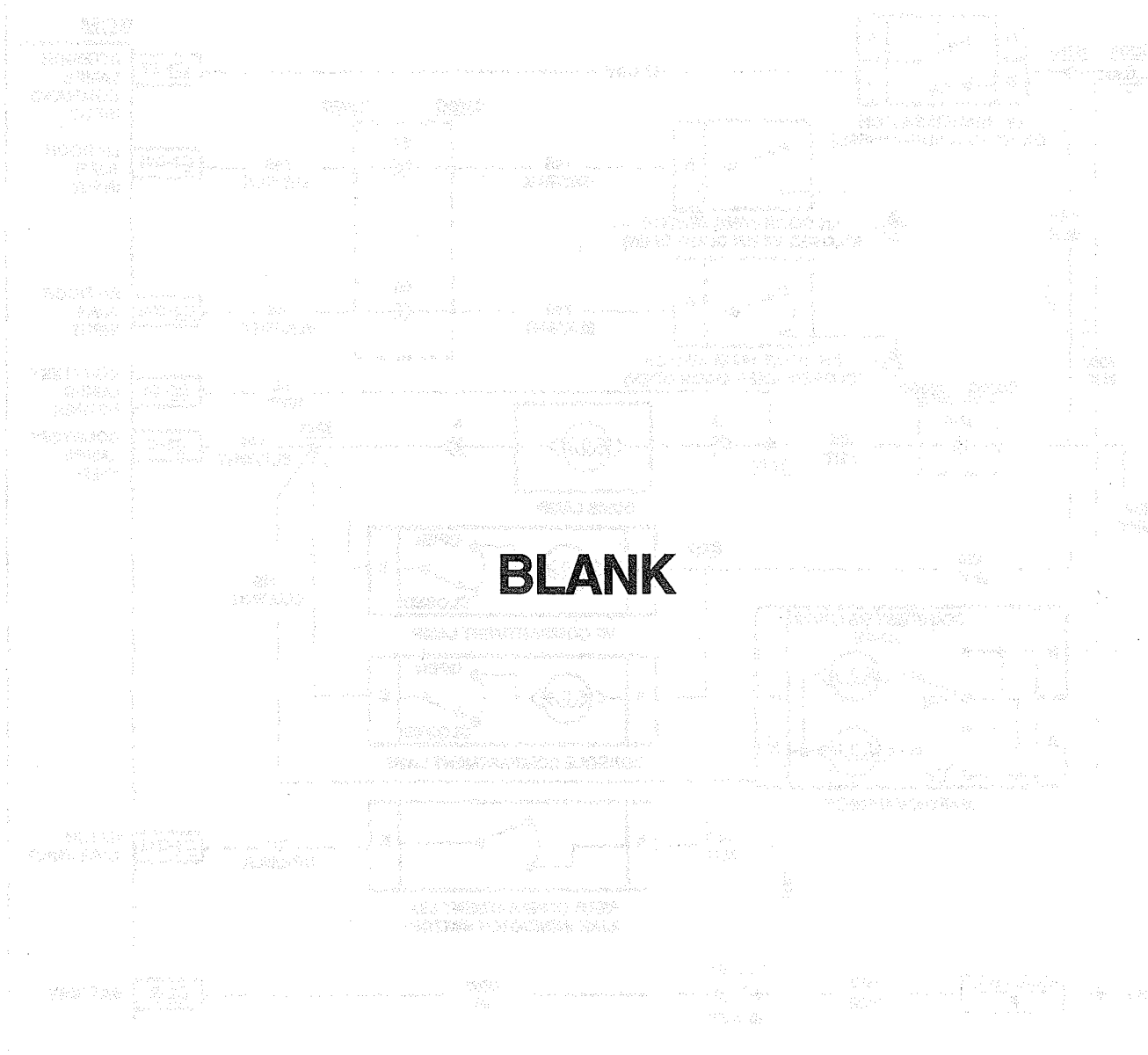

8D-8 BODY CONTROL MODULE

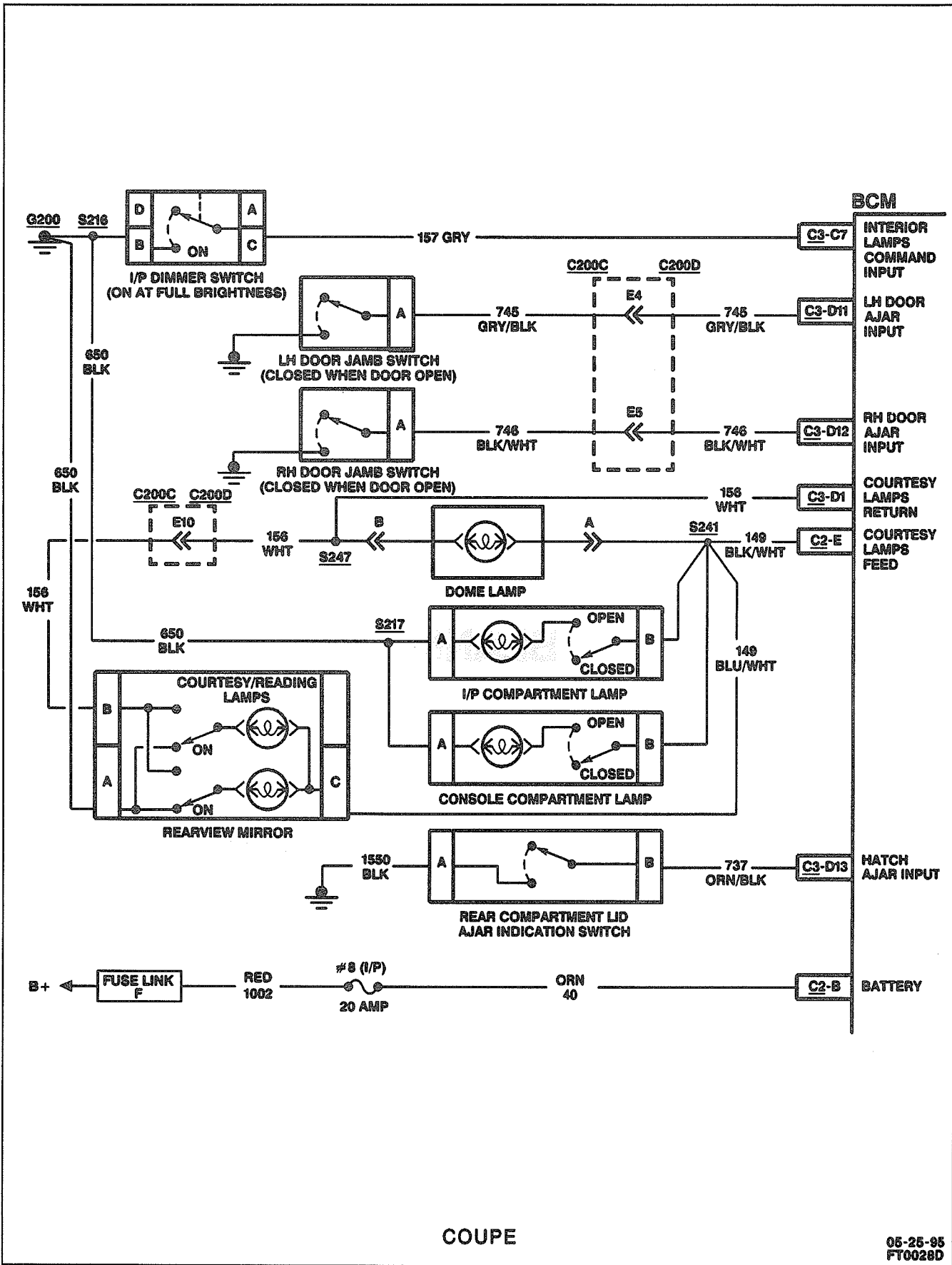

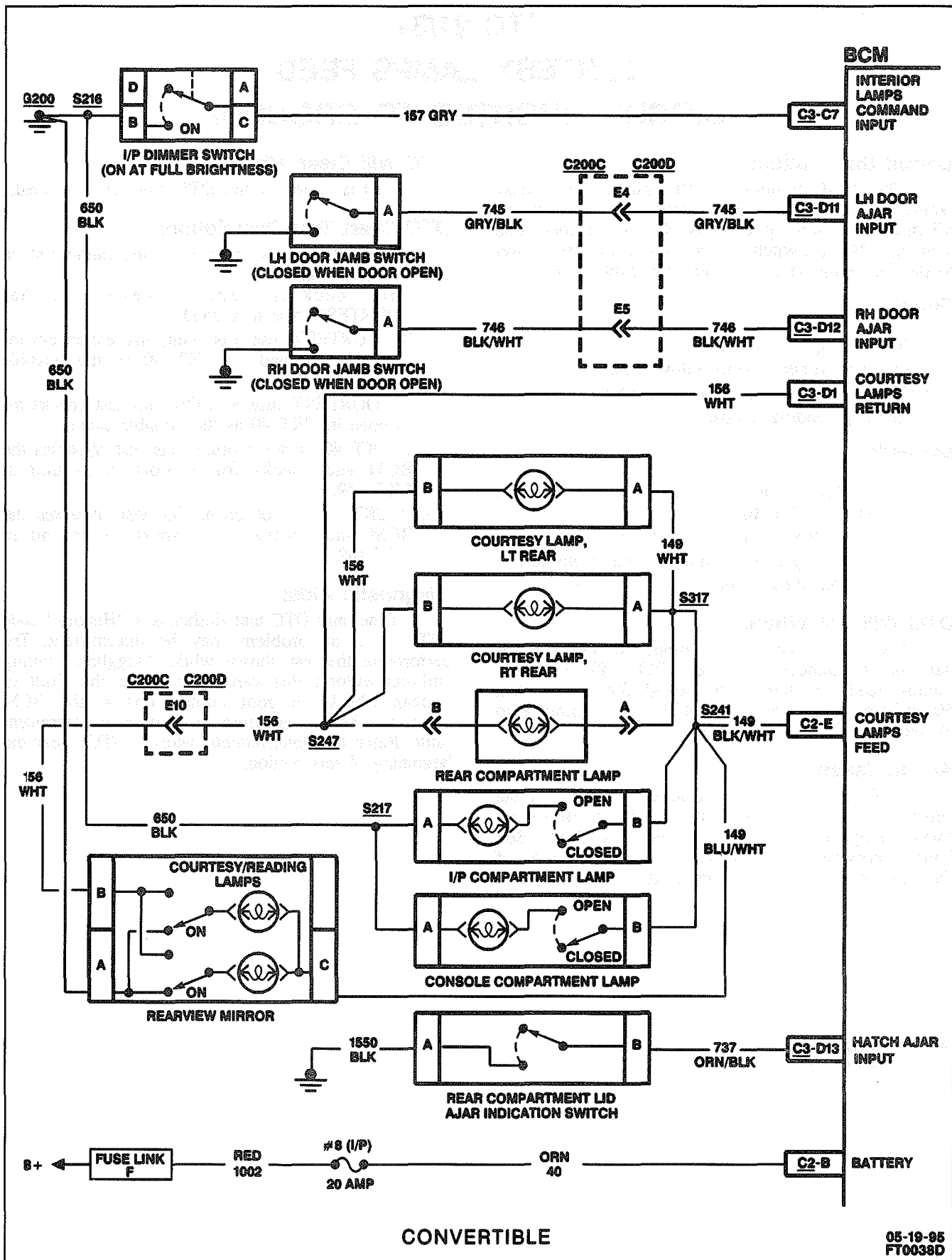

DTC 21/31

COURTESY LAMPS FEED (CIRCUIT SHORTED TO GROUND)

Circuit Description:

The BCM provides 12 volt input to the courtesy lamps on CKT 149 to S241 when commanded by the I/P dimmer switch input, or the RH or LH door jamb switch, or Hatch Switch inputs. S241 distributes power to the following on coupe and convertible models:

Coupe

- Dome Lamp.
- I/P Compartment Lamp (Glove Box).
- Console Compartment Lamp (Center Console).
- Courtesy/Reading lamps.

Convertible

- S317 (RH/LH Rear Courtesy Lamps, Rear Compartment Lamp).
- I/P Compartment Lamp (Glove Box).
- Console Compartment Lamp (Center Console).
- Courtesy/Reading Lamps.

DTC Will Set When:

CKT 40 is open due to either Courtesy Fuse 8, harness or connector failure; CKT 149 (Courtesy Lamps Feed) is shorted to ground for greater than 50 milliseconds, while the BCM is attempting to Power this circuit; or BCM is defective.

Action Taken:

DTC 21 will set. No Courtesy lighting in the vehicle; Interior Lamp Switch next to Headlamp Switch inoperative. Center console and Glove Box Lamps inoperative. BCM will read out a series of flash DTCs upon entering Diagnostic Mode.

DTC Will Clear When:

Fault is corrected and DTC memory is cleared.

DTC Chart Test Description:

Number(s) below refer to circled number(s) on the diagnostic chart.

1. This check is made to make sure that COURTESY fuse 8 is good.
2. If COURTESY fuse 8 is open, this test checks for a short to ground on CKT 40 as the possible cause.
3. If COURTESY fuse 8 is OK, this test checks for an open in CKT 40 as the possible cause.
4. If CKT 40 is not shorted, this test bypasses the BCM and checks for a short to ground in CKT 149.
5. If CKT 40 is not open, this test bypasses the BCM and checks for a short to ground in CKT 149.

Diagnostic Aids:

If the only DTC that flashes is a "History" code (DTC 31), the problem may be intermittent. Try performing the test shown while "wiggling" wiring and connectors; this can often cause the fault to appear. Check for poor connections at the BCM connector. these could cause an open or an intermittent fault. Refer to "Intermittent/History" DTCs near the beginning of this section.

DTC 21/31 COURTESY LAMPS CIRCUIT

! IMPORTANT: CHECK FOR PROPER INSTALLATION OF AFTERMARKET ELECTRONIC EQUIPMENT WHICH MAY AFFECT THE INTEGRITY OF THIS SYSTEM.

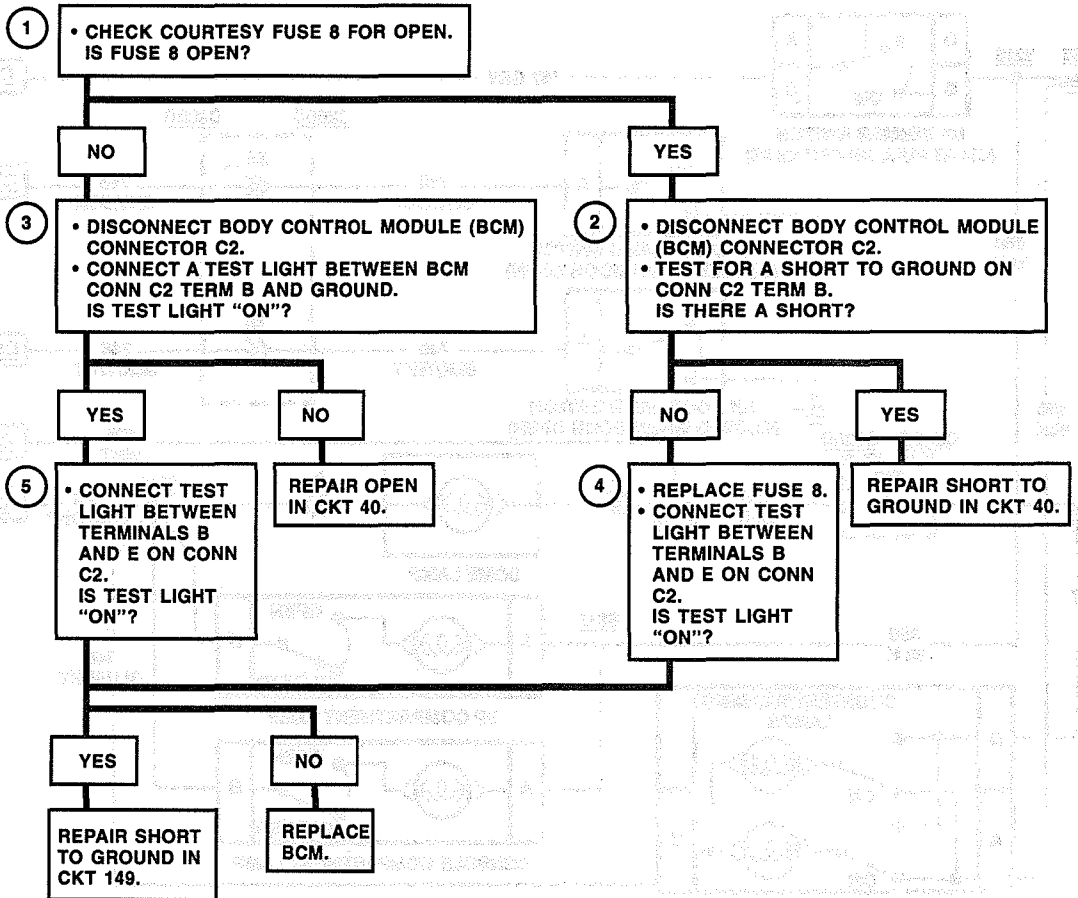

8D-12 BODY CONTROL MODULE

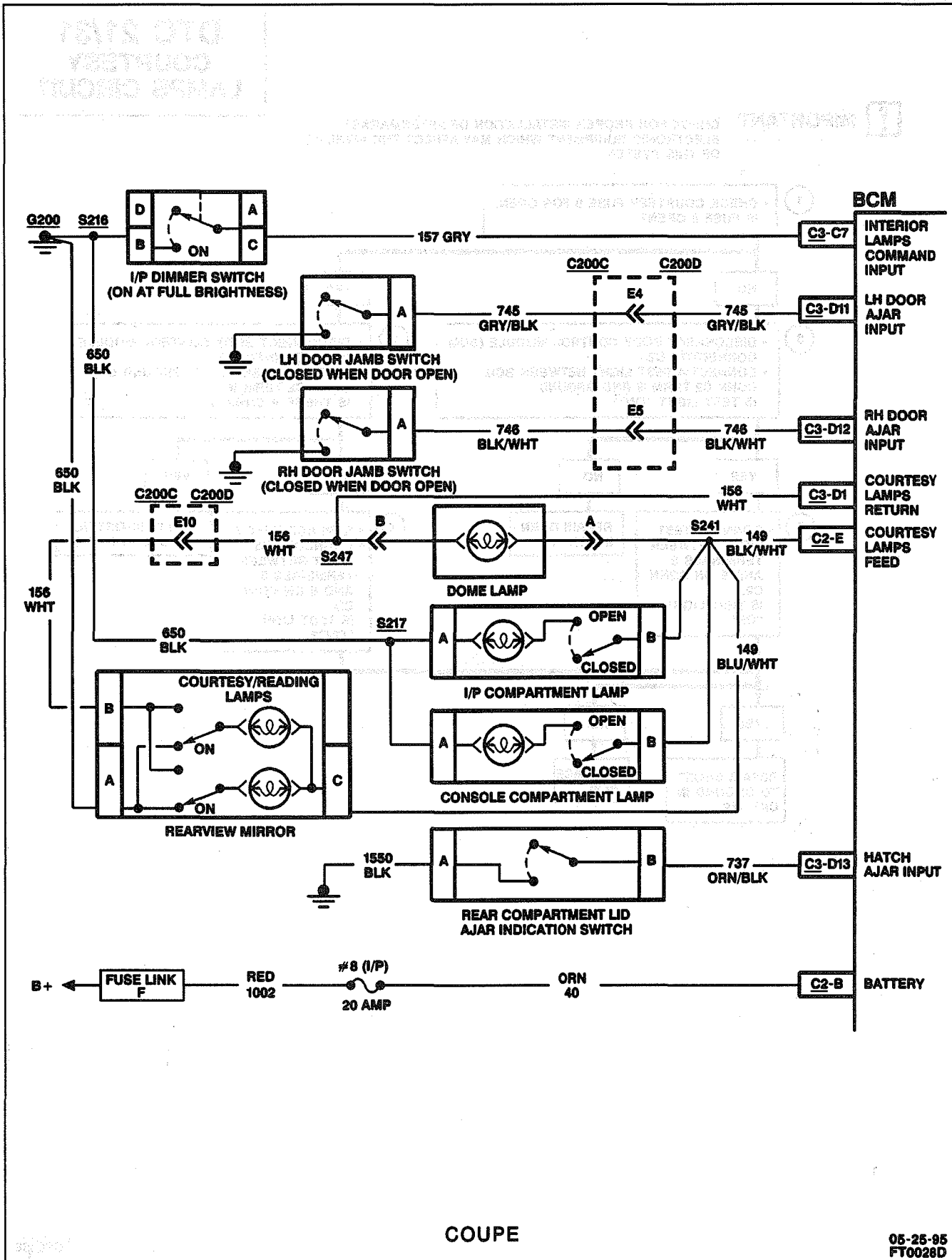

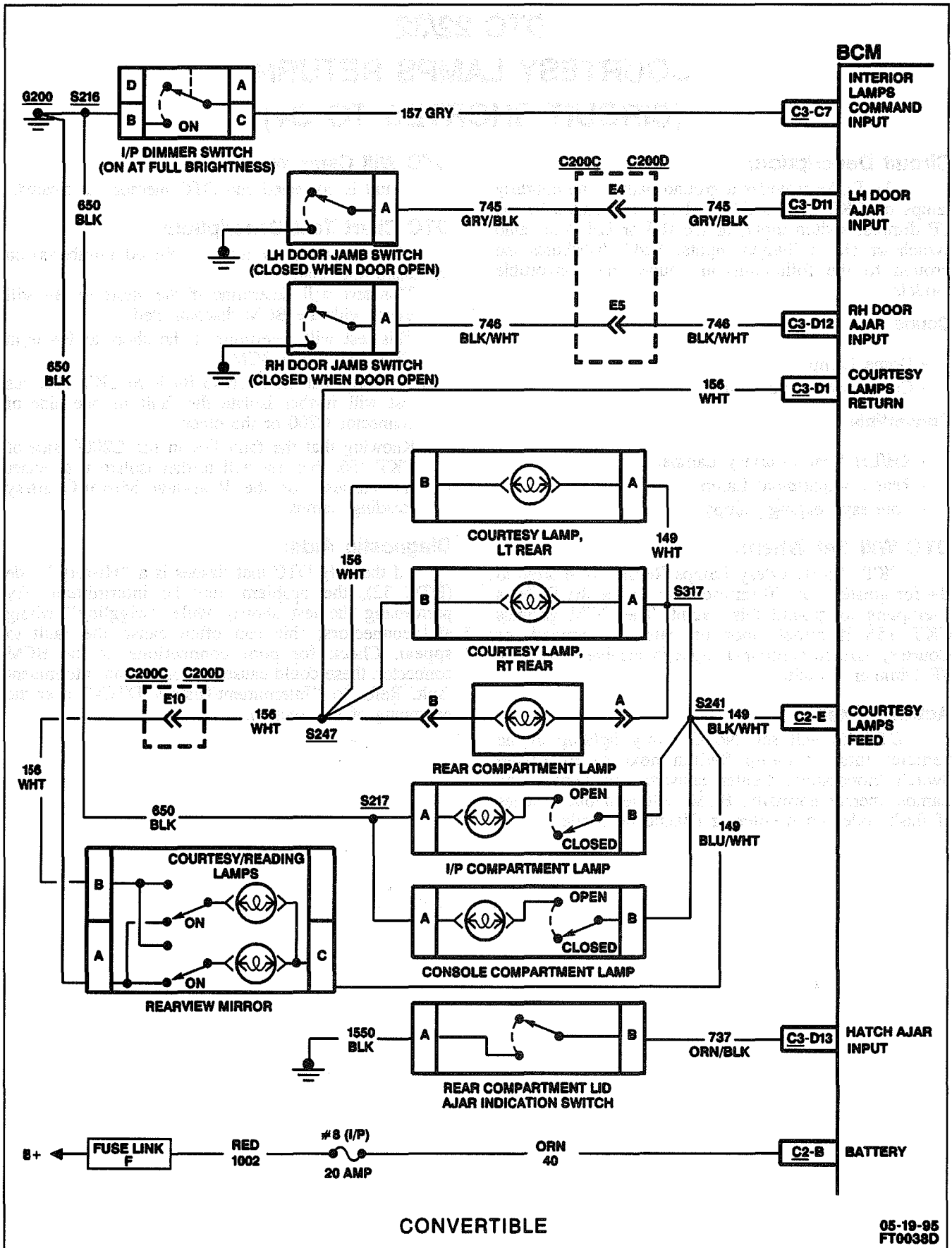

CONVERTIBLE

DTC 22/32

COURTESY LAMPS RETURN (CIRCUIT SHORTED TO B+)

Circuit Description:

The BCM provides a ground path to the courtesy lamps on CKT 156 to S247 when commanded by the I/P dimmer switch input, or the RH or LH door jamb switch or Hatch Switch inputs. S247 distributes the ground to the following on coupe and convertible models:

Coupe

- Dome Lamp.
- Courtesy/Reading lamps.

Convertible

- RH/LH Rear Courtesy Lamps.
- Rear Compartment Lamp.
- Courtesy/Reading Lamps.

DTC Will Set When:

CKT 156 (Courtesy Lamps Return) is shorted to B+ for greater than 50 milliseconds, while the BCM is attempting to ground this circuit. The BCM grounds CKT 156 if either door or hatch is opened, or Courtesy Lamps command input is received from the I/P Dimmer Switch.

Action Taken:

DTC 22 will set. No Courtesy lighting in the vehicle; Interior Lamp Switch next to Headlamp Switch Inoperative. Center console and Glove Box Lamps operate normally. BCM will read out a series of flash codes upon entering Diagnostic Mode.

DTC Will Clear When:

Fault is corrected and DTC memory is cleared.

DTC Chart Test Description:

Number(s) below refer to circled number(s) on the diagnostic chart.

1. This test will determine if the short to B+ still exists with the BCM disconnected.
2. This test will determine if the short to B+ is in CKT 156 or the BCM.
3. Knowing that the Short to B+ is in CKT 156, this test will further isolate the fault to one side of connector C200 or the other.
4. Knowing that the fault lies in the C200C side of CKT 156, this test will further isolate it to either the harness, or the Rearview Mirror/Courtesy Reading Lamps.

Diagnostic Aids:

If the only DTC that flashes is a "History" code (DTC 32), the problem may be intermittent. Try performing the test shown while "wiggling" wiring and connectors; this can often cause the fault to appear. Check for poor connections at the BCM connector. these could cause an open or an intermittent fault. Refer to "Intermittent/History DTCs" near the beginning of this section.

**DTC 22/32
COURTESY
LAMPS CIRCUIT**

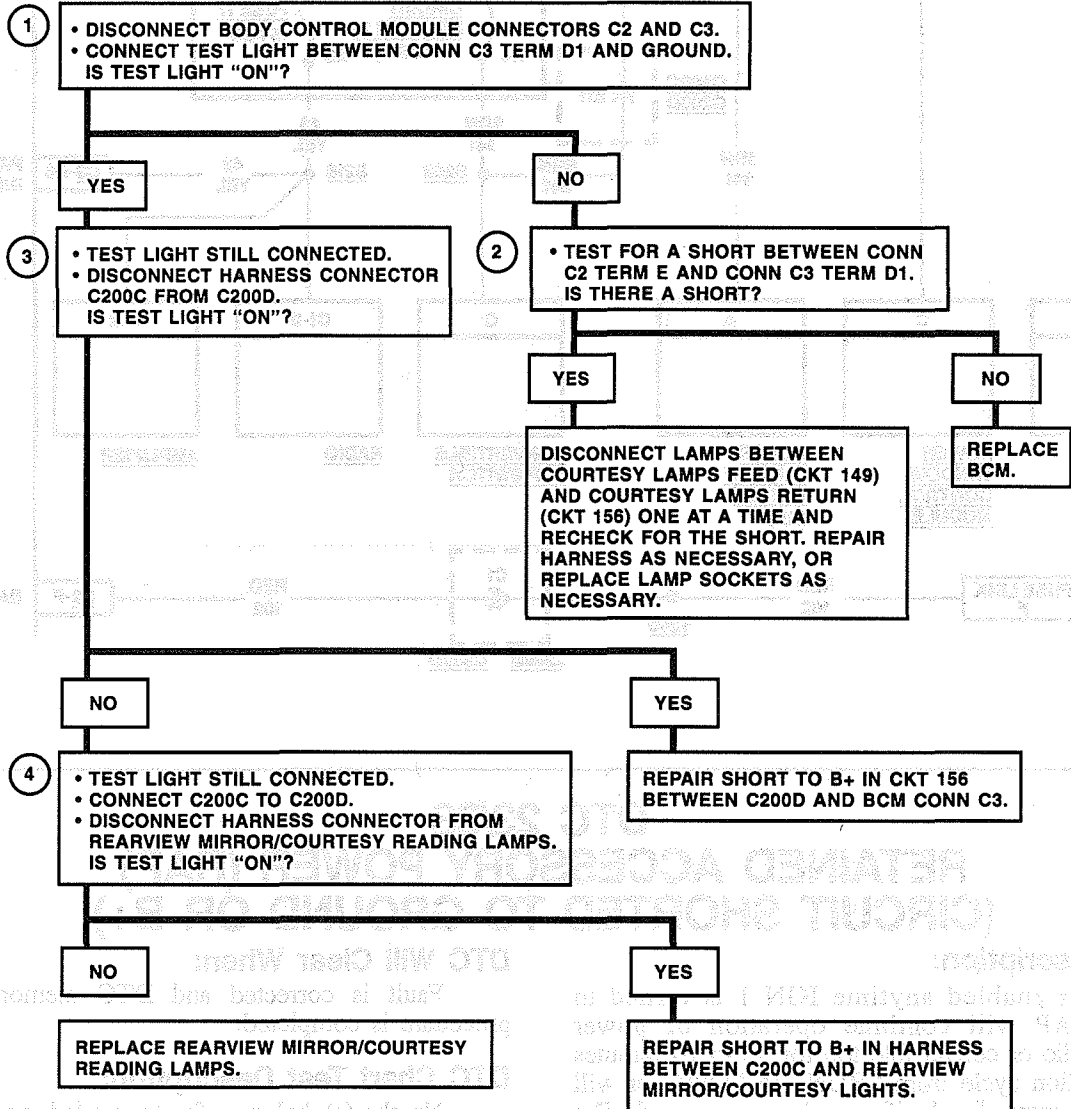

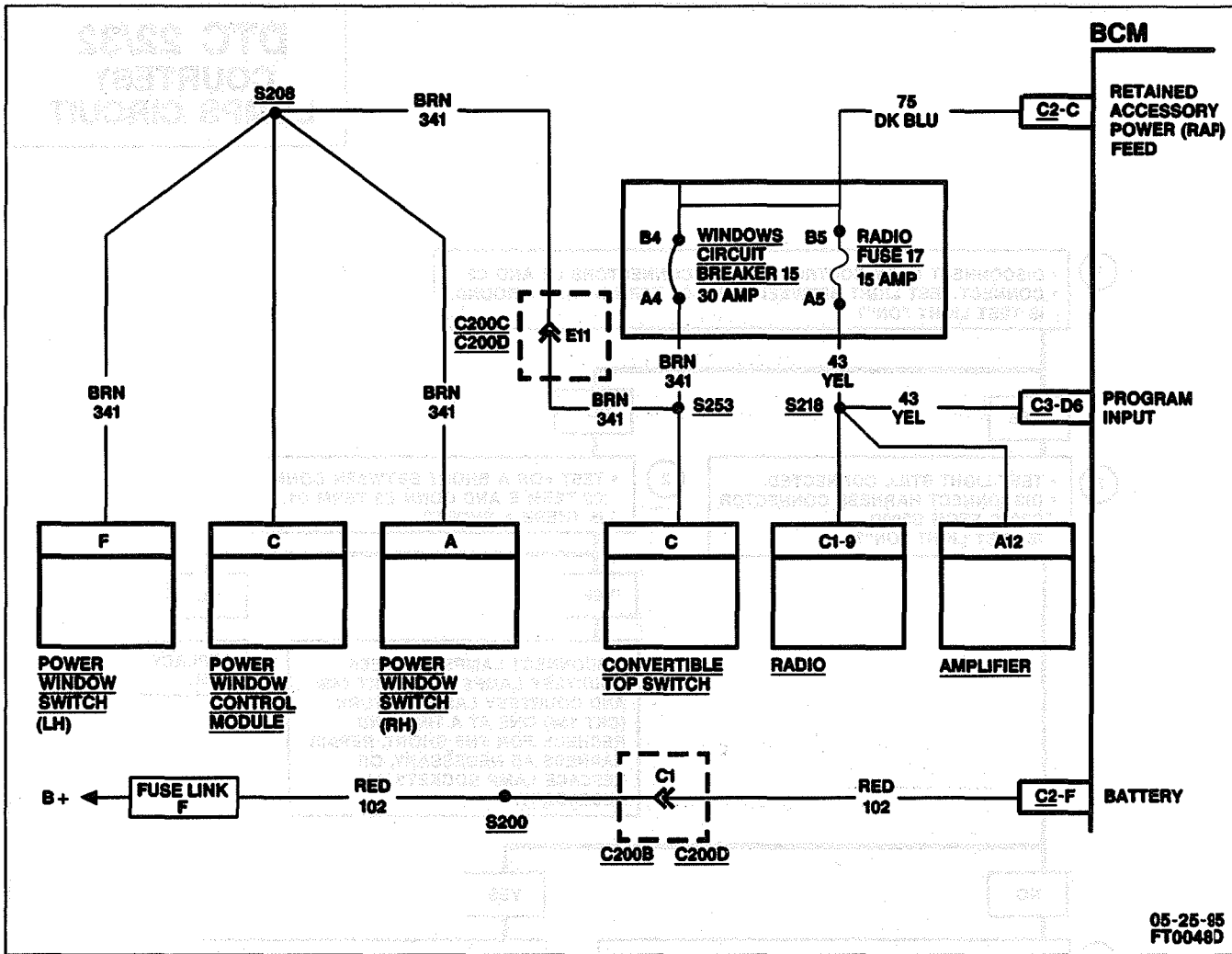

05-25-85
FT0048D

DTC 23/33 RETAINED ACCESSORY POWER (RAP) (CIRCUIT SHORTED TO GROUND OR B+)

Circuit Description:

RAP is enabled anytime IGN 1 is turned to "RUN." RAP will continue operation of power windows, radio or convertible top for up to 10 minutes after an ignition cycle from "RUN" to "OFF" or will shut "OFF" immediately if any door is opened. The BCM provides the RAP function through CKT 75 to WINDOWS Circuit Breaker 15 and RADIO fuse 17 in the I/P fuse block.

DTC Will Set When:

The BCM detects that the RAP output on CKT 75 is either shorted to ground (while RAP is enabled), or shorted to B+ (while RAP is disabled) for more than 50 milliseconds.

Action Taken:

DTC 23 will set. RAP feature will not function (if shorted to ground), or RAP feature will not deactivate when door is opened (if shorted to B+). BCM will read out a series of flash codes upon entering Diagnostic Mode.

DTC Will Clear When:

Fault is corrected and DTC memory clearing procedure is completed.

DTC Chart Test Description:

Number(s) below refer to circled number(s) on the diagnostic chart.

1. This test checks for an open in CKT 102.
2. If CKT 102 is OK, this test checks for a short to B+ in CKT 75.
3. If CKT 75 is not shorted to B+, this test checks for a short to ground in CKT 75 or a defective BCM.

Diagnostic Aids:

If the only DTC that flashes is a "History" code (DTC 33), the problem may be intermittent. Try performing the test shown while "wiggling" wiring and connectors; this can often cause the fault to appear. Check for poor connections at the BCM connector. these could cause an open or an intermittent fault. Refer to "Intermittent/History DTCs" near the beginning of this section.

**DTC 23/33
RETAINED
ACCESSORY
POWER (RAP)**

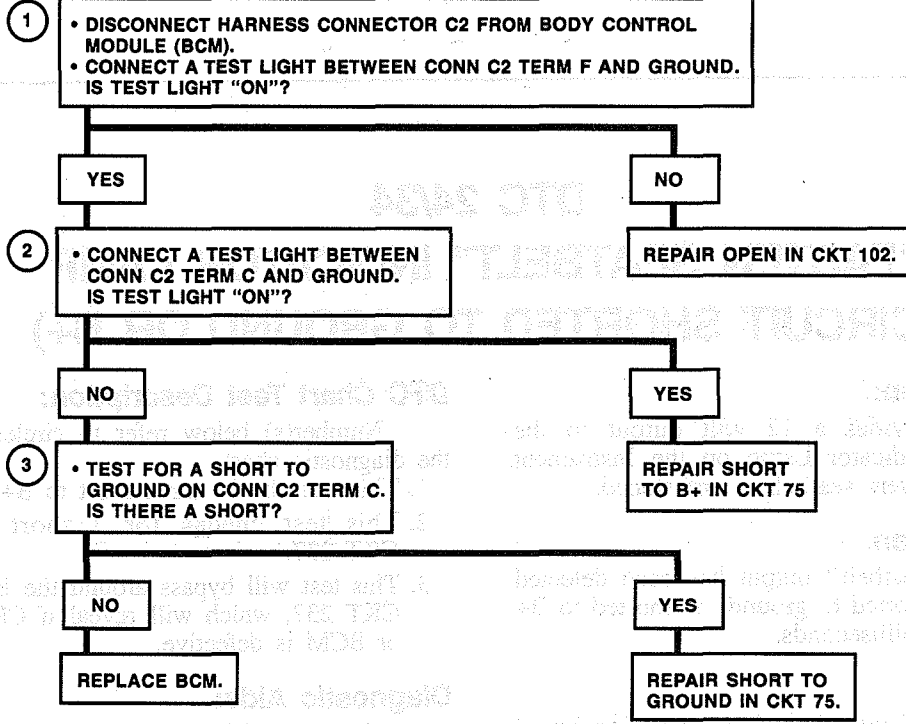

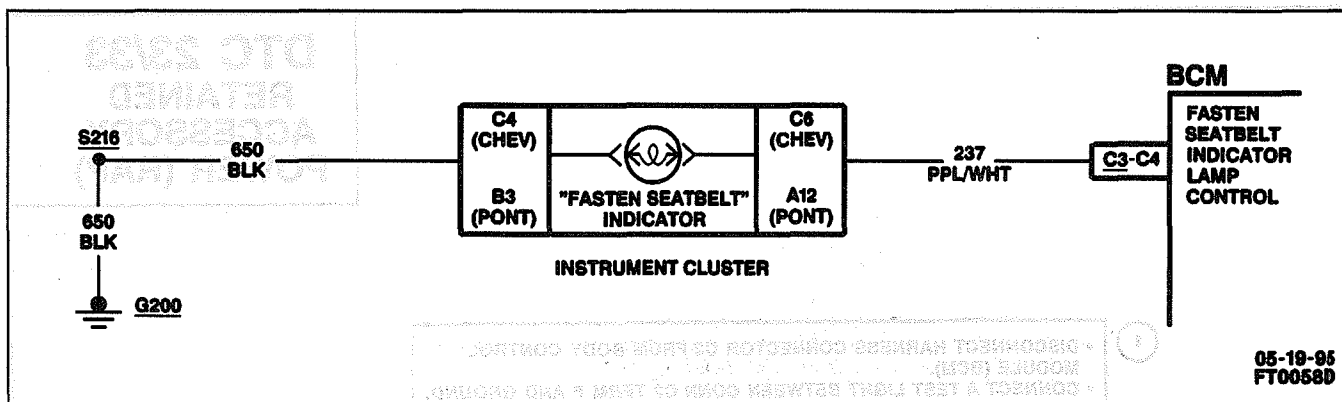

DTC 24/34

"FASTEN SEATBELT" INDICATOR LAMP (CIRCUIT SHORTED TO GROUND OR B+)

Circuit Description:

The BCM provides a 12 volt output to the "Fasten Seatbelt" Indicator Lamp on the Instrument Cluster while the drivers seatbelt is unfastened.

DTC Will Set When:

The "Fasten Seatbelt" output has been detected by the BCM to be shorted to ground, or shorted to B+ for greater than 50 milliseconds.

Action Taken:

DTC 24 will set. The "Fasten Seatbelt" indicator lamp will not illuminate when ignition is "ON" and the drivers' seatbelt is not fastened, or "Fasten Seatbelt" indicator is always on.

DTC Will Clear When:

Fault is corrected and DTC memory clearing procedure is completed.

DTC Chart Test Description:

Number(s) below refer to circled number(s) on the diagnostic chart.

1. This test checks for a short to B+ in CKT 237.
2. This test checks for a short to ground in CKT 237.
3. This test will bypass around the BCM directly to CKT 237, which will reveal if CKT 237 is open or BCM is defective.

Diagnostic Aids:

If the only DTC that flashes is a "History" code (DTC 34), the problem may be intermittent. Try performing the test shown while "wiggling" wiring and connectors; this can often cause the fault to appear. Check for poor connections at the BCM connector. these could cause an open or an intermittent fault. Refer to "Intermittent/History DTCs" near the beginning of this section.

**DTC 24/34
FASTEN
SEATBELT
INDICATOR
CIRCUIT**

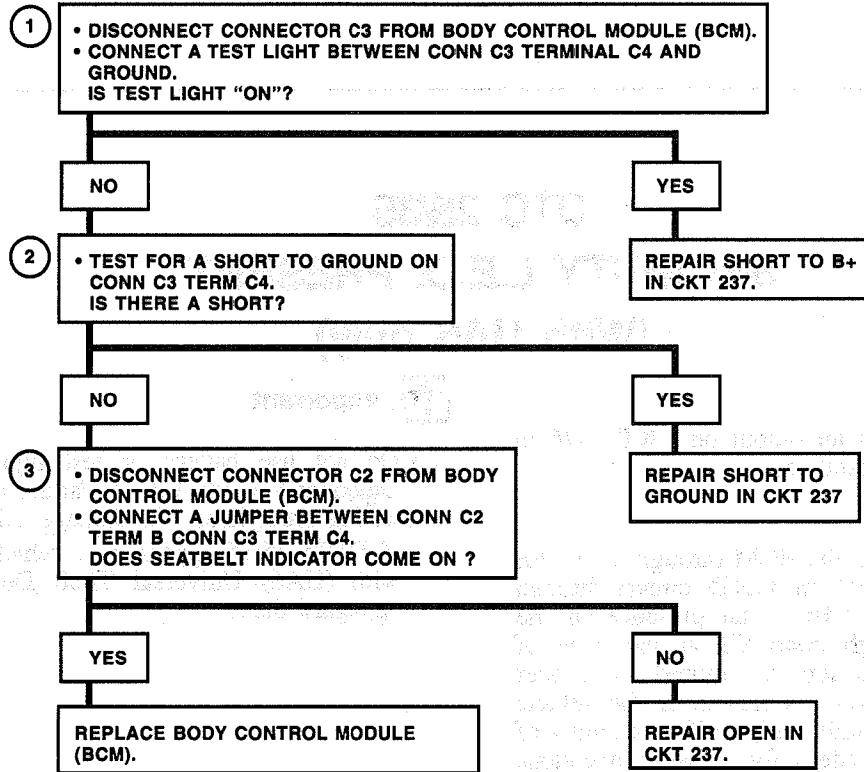

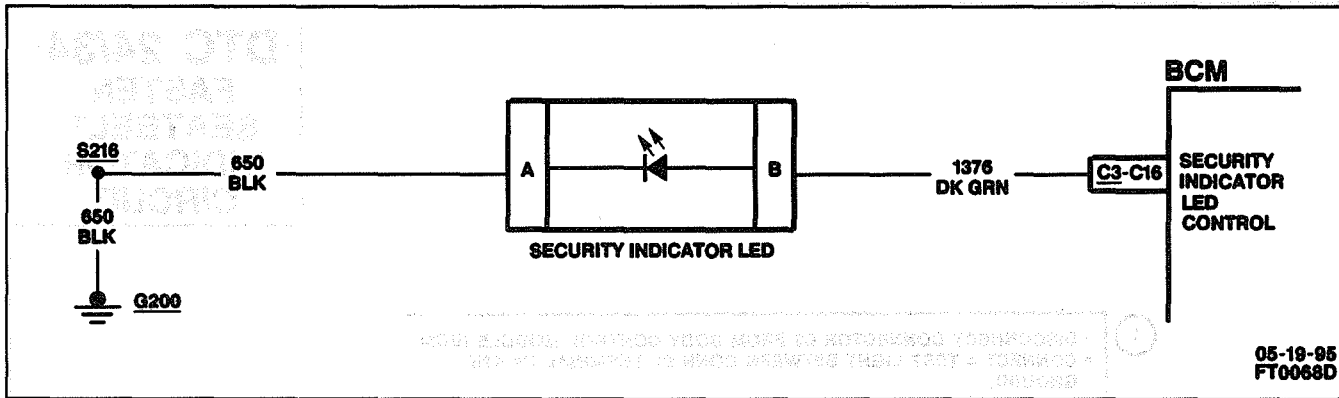

DTC 25/35 SECURITY L.E.D. PRESENT (With UA6 only)

Circuit Description:

The BCM provides an output on CKT 1376 to the Security L.E.D. (if installed).

DTC Will Set When:

Battery is applied to the BCM through connector C2 and the BCM "sees" an L.E.D circuit through connector C3 terminal "C16". The presence of the L.E.D. connected through conn C3 at the time of battery (conn C2) connection is required for proper UTD operation. If the L.E.D. is present on the vehicle and DTCs 25/35 are not indicated, verify continuity of CKTs 1376 and 650 and check for proper connections at BCM conn C3 and at L.E.D., then disconnect and reconnect conn C2 to the BCM.

! Important

- Do not use battery or test light to test Theft Deterrent Security L.E.D. Failure to follow proper testing procedures will damage L.E.D.
- If DTCs 25/35 appear in a vehicle not equipped with (UA6) Universal Theft Deterrent System, disregard them.

REMOTE CONTROL DOOR LOCK TRANSMITTER DTCs



Important

- DTCs 41 through 45 will set only while the BCM is in the Diagnostic Mode, and a button on the face of the Remote Control Door Lock Transmitter has been pressed. These DTCs are used to determine the RF performance of the Remote Control Door Lock Transmitter, and the receiver in the BCM.

DTC 41

Last Transmitter Message Received Valid (With AU0 only)

Malfunction/Condition:

The digital RF message received from the Remote Control Door Lock Transmitter was valid, all security checks passed. No Malfunction.

Operational Effects:

Correct Remote Control Door Lock Transmitter functionality should be observed (i.e. Lock, Unlock, etc.).

Potential Causes:

If Remote Control Door Lock Transmitter digital RF message is sent, but a DTC 41 is not set (or any other DTC 42-45), then Remote Control Door Lock Transmitter may be defective. If Remote Control Door Lock Transmitter digital RF message is sent and DTC 41 is set, but the corresponding function does not take place, the BCM or harness may be defective.

Comments:

None.

DTC 42

Last Transmitter Message Received had Invalid ID (With AU0 only)

Malfunction/Condition:

The digital RF message received was from a Remote Control Door Lock Transmitter not assigned to the BCM.

Operational Effects:

No remote function capability (i.e. Lock, Unlock, etc.).

Potential Causes:

A Remote Control Door Lock Transmitter was used without programming it to the BCM. If the Remote Control Door Lock Transmitter was already programmed, it may be defective.

Comments:

The BCM should be put into the Remote Control Door Lock Transmitter programming mode. Both Remote Control Door Lock Transmitters must be reassigned to the BCM at the same time. Refer to Section 9K.

DTC 43

Last Transmitter Message Received had Sumcheck Error ()

(With AU0 only)

Malfunction/Condition:

The digital RF message received was from a Remote Control Door Lock Transmitter that is programmed to the BCM, but the message did not pass the sumcheck security test.

Operational Effects:

No remote function capability (i.e. Lock, Unlock, etc.).

Potential Causes:

The Remote Control Door Lock Transmitter is out of sync with the BCM. This can be caused by the Remote Control Door Lock Transmitter buttons being pressed more than 256 times out of range of the BCM. It can also be caused by changing the Remote Control

Door Lock Transmitter's battery and pushing the transmitter's buttons more than 10 times out of range of the BCM. This Malfunction could also be encountered if the digital RF message has an error due to noise from the surrounding environment or if the Remote Control Door Lock Transmitter itself is defective.

Comments:

The most likely cause is the Remote Control Door Lock Transmitter is out of sync. To resync the transmitter, press "Lock" and "Unlock" buttons on the Remote Control Door Lock Transmitter at the same time for 5 seconds. This will resync the Remote Control Door Lock Transmitter to the BCM.

DTC 44

Last Transmitter Message Received had Encryption Error ()

(With AU0 only)

Malfunction/Condition:

The digital RF message received was from a Remote Control Door Lock Transmitter that is programmed to the BCM, but the message did not pass the encryption security test.

Operational Effects:

No remote function capability (i.e. Lock, Unlock, etc.).

Potential Causes:

The Remote Control Door Lock Transmitter has been in the program or resync mode out of range of the BCM. This Malfunction could also be encountered

if the digital RF message has an error due to noise from the surrounding environment or if the Remote Control Door Lock Transmitter itself is defective.

Comments:

The most likely cause is the Remote Control Door Lock Transmitter has resynced out of the range of the BCM. To resync the Remote Control Door Lock Transmitter, press "Lock" and "Unlock" buttons on the Transmitter at the same time for 5 seconds. This will resync the Remote Control Door Lock Transmitter to the BCM.

DTC 45

Receiver Processing Currently in 20 Second Lockout (With AU0 only)

Malfunction/Condition:

At least 50 consecutive digital RF messages were received from a Remote Control Door Lock Transmitter that is programmed to the BCM, but the messages did not pass the encryption security test. The BCM will cease processing any Remote Control Door Lock Transmitter digital RF messages (good or bad) for 20 seconds.

Operational Effects:

No remote function capability (i.e. Lock, Unlock, etc.).

Potential Causes:

The Remote Control Door Lock Transmitter has been in the resync or program mode out of range of the BCM. This Malfunction could also be encountered if the Remote Control Door Lock Transmitter itself is defective.

Comments:

The most likely cause is the Remote Control Door Lock Transmitter has resynced out of the range of the BCM. To resync the Remote Control Door Lock Transmitter, press "Lock" and "Unlock" buttons on the Transmitter at the same time for 5 seconds. This will resync the Remote Control Door Lock Transmitter to the BCM. This Malfunction Could be induced prior to the BCM entering the Diagnostic Mode.

DTC 55

Begin Configuration Display

Condition:

Code 55 is displayed to indicate the next two numbers displayed are BCM hardware and software configurations. The first number following 55 is the hardware configuration, the second number is the software configuration. Code 55 and the two configuration numbers are always displayed.

Comments:

After the configuration code numbers are displayed, the entire DTC list is repeated beginning with DTC 12.